

ONKYO SERVICE MANUAL

SYNTHESIZED FM STEREO/AM TUNER MODEL T-4087

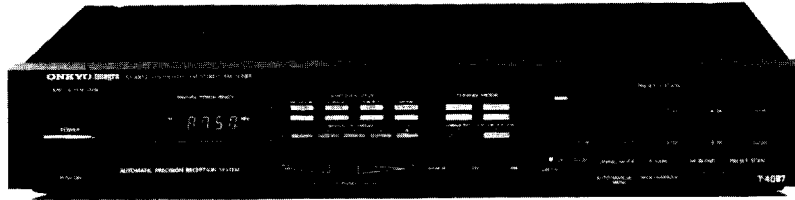

Silver and black models

UD, UDN, BUD, BUDN	120V AC, 60Hz
UG, BUG	220V AC, 50Hz
UW, BUW	120 or 220V AC, 50/60Hz
UQA, UQB	240V AC, 50Hz

SAFETY-RELATED COMPONENT WARNING!!

COMPONENTS IDENTIFIED BY MARK Δ ON THE SCHEMATIC DIAGRAM AND IN THE PARTS LIST ARE CRITICAL FOR RISK OF FIRE AND ELECTRIC SHOCK. REPLACE THESE COMPONENTS WITH ONKYO PARTS WHOSE PART NUMBERS APPEAR AS SHOWN IN THIS MANUAL.

MAKE LEAKAGE-CURRENT OR RESISTANCE MEASUREMENTS TO DETERMINE THAT EXPOSED PARTS ARE ACCEPTABLY INSULATED FROM THE SUPPLY CIRCUIT BEFORE RETURNING THE APPLIANCE TO THE CUSTOMER.

TABLE OF CONTENTS

Specifications	2
Service procedures	2
Block diagram	3
Exploded view	4
Parts list	5
Microcomputer operation	6
Adjustment procedures	8
IC block diagram	11
Printed circuit board view	15
Schematic diagram	17
Pc board-parts list	19
Packing view	24

ONKYO
AUDIO COMPONENTS

SPECIFICATIONS

FM:

Tuning Range:	87.9 – 107.5 MHz (200kHz steps) (D) 87.50 – 108.00 MHz (50kHz steps) (G/W)
Usable Sensitivity:	Mono: 10.3dBf, 0.9µV, IHF (75Ω) Stereo: 17.2dBf, 2.0µV
50dB Quieting Sensitivity:	Mono: 16.0dBf, 1.7µV Stereo: 36.0dBf, 17µV
Capture Ratio:	1.0dB
Image Rejection Ratio:	100dB
IF Rejection Ratio:	100dB
Signal-to-Noise Ratio:	Mono: 85dB Stereo: 77dB
Alternate Channel Attenuation:	80dB IHF (±400kHz) (Narrow) (D)
Selectivity:	80dB DIN (Narrow) (±300kHz, 40kHz Dev.) (G)
AM Suppression Ratio:	55dB
Total Harmonic Distortion:	Mono: 0.03% Stereo: 0.07% (wide)
Frequency Response:	30 – 15,000Hz +0.5dB/ –1.5dB
Stereo Separation:	45dB at 1kHz 33dB at 70 – 10,000Hz
Output Voltage:	0 ~ 1.5V
Muting Level:	17.2dBf, 4.0µV

AM:

Tuning Range:	522 – 1611kHz (9kHz steps) (G) 530 – 1610kHz (10kHz steps) (D)
Usable Sensitivity:	25µV
Image Rejection Ratio:	40dB
IF Rejection Ratio:	40dB
Signal-to-Noise Ratio:	40dB
Total Harmonic Distortion:	0.7%
Output Voltage:	0 ~ 400mV

General

Antennas:	FM: coaxial terminal AM: built-in loop antenna and external terminal
Semiconductors:	FETs: 8 TR: 39 ICs: 20 Diodes: 96 LEDs: 31
Dimensions (WxHxD):	435 x 77 x 372mm (17-18" x 3" x 14-5/8")
Weight:	4.4kg., 9.7lbs. (G)
Dimensions (WxHxD): (with side panels)	465 x 77 x 372mm (18-3/8" x 3" x 14-5/8")
Weight: (with side panels)	5.1kg., 11.2lbs (D)

Specifications and features are subject to change without notice.

SERVICE PROCEDURES

1. Replacement of lamp

This unit is used two lamps listed below.

Circuit no.	Part no.	Description
PL001	210149	PL14V0.06AW-3.0, Power indicator
PL902	210064A	PL6.3V, 250mA, Dial plate illumination

2. Safety-check output

(Only U.S.A. model)

After correcting the original service problem, perform the following safety check before releasing the set to the customer. Connect the insulating-resistance tester between the plug of power supply cord and nickel screw on the back panel.

Specifications: 3.3Mohm ± 10% at 500V.

3. Change of band step/de-emphasis

Universal models are equipped with a band step/de-emphasis switch on the back panel. This switch is set to following position.

	Emphasis	AM step
set position	50µsec.	9 kHz
other	75µsec.	10 kHz

4. Change of voltage

Universal models are equipped with a voltage selector to conform with local power supplies. This switch is located on the back panel. Be sure to set this switch to match the voltage of the power supply in your area before tuning the power switch on.

This switch is set to 220V at the factory. Voltage is changed by sliding the groove in the switch with the screwdriver to the right or left. Confirm that the switch has been moved all the way to the right or left before turning the power switch on.

5. Memory preservation

This unit does not require memory preservation batteries. A built-in memory power back-up system preserves contents of the memory during power failures and even when the unit is unplugged. The unit must be plugged in and the power switch turned on and off once in order to charge the super capacitor of C409. Note that since this is not a permanent memory, the power switch must be turned on and off a few times each month to keep the back-up system operable. The period of time during which memory contents are preserved after power has last been turned off varies depending on climate and the location and placement of the unit. On the average, memory contents are protected over a period of 2 weeks after the last time power has been turned off. This period is shorter when the unit exposed to very high humidity or used in an area with an extremely humid climate.

BLOCK DIAGRAM

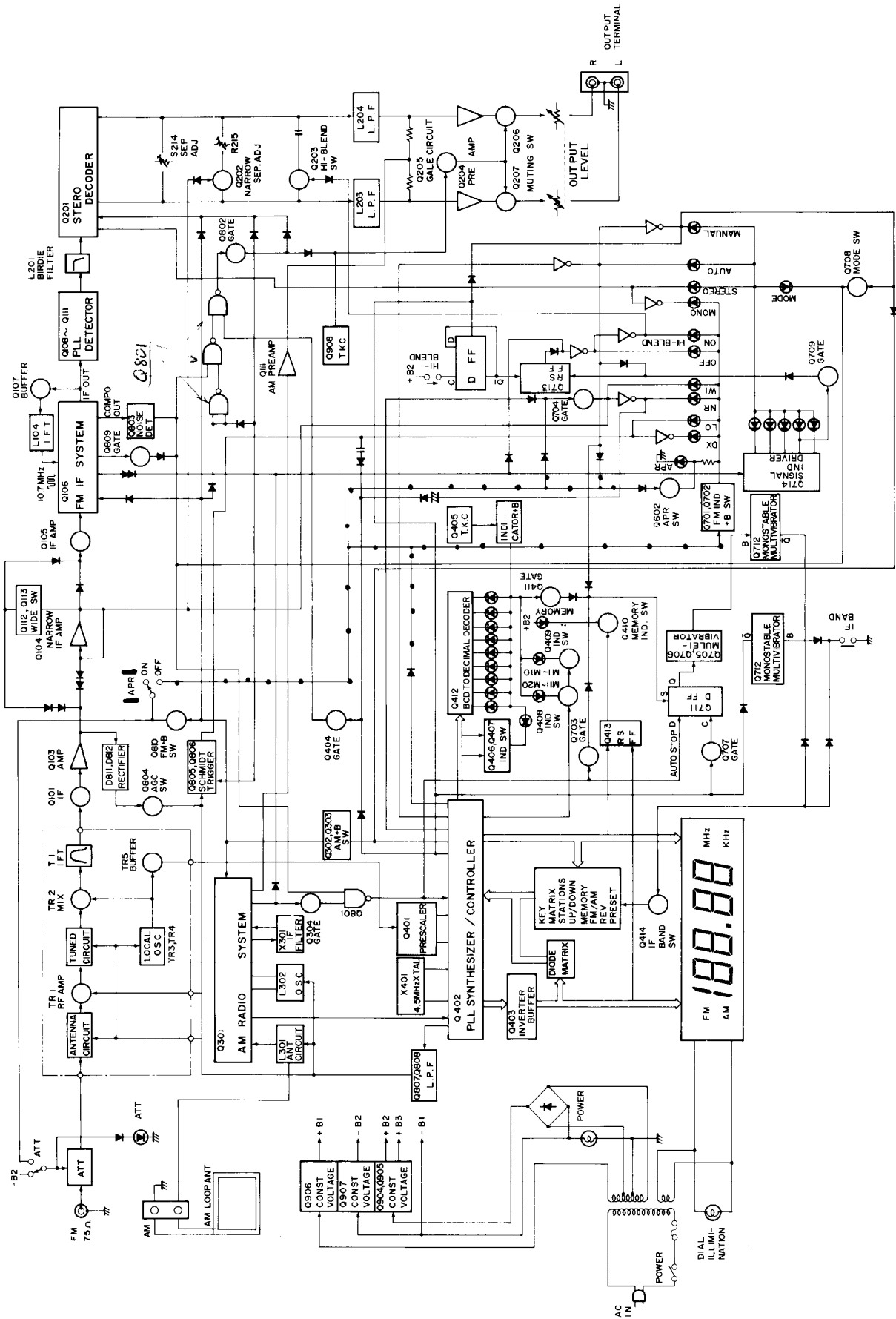

EXPLODED VIEW

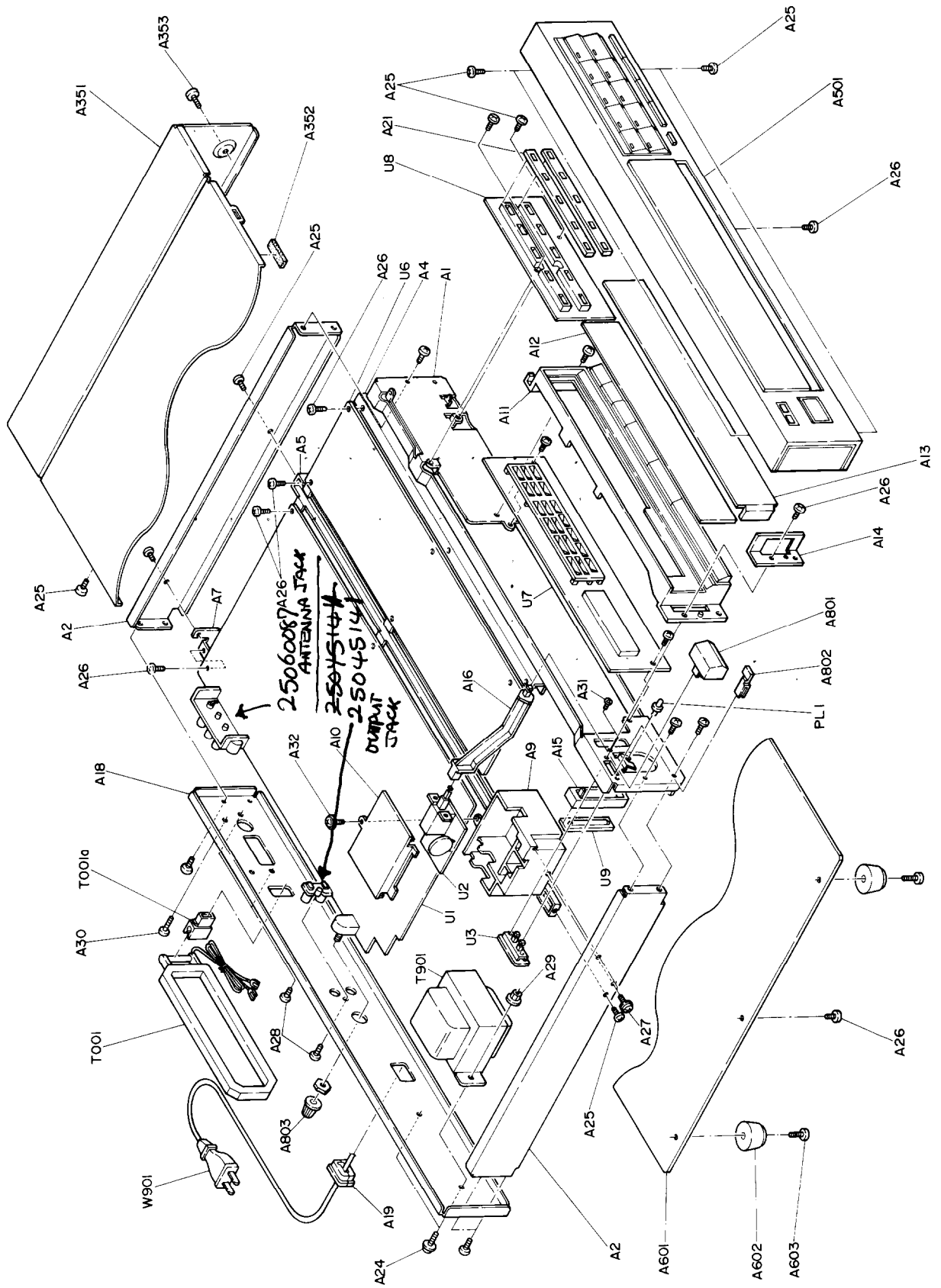

PARTS LIST

REF. NO.	PART NO.	DESCRIPTION	REF. NO.	PART NO.	DESCRIPTION	REF. NO.	PART NO.	DESCRIPTION
A1	27110242-1B	Front bracket	A351	28184188	Top cover <S>	U1	18568516	NARF-2416-1, Main circuit pc board ass'y <D>
A2	27115014G	Side bracket		28184183	Top cover 			board ass'y <D>
A4	27130406	Bracket F	A352	28140020	4x10x40, Cushion		18564516A	NARF-2416-1A, Main circuit pc board ass'y <G>
A5	27130407A	Bracket C	A353	838440089	4TTB+8C (BC), Tapping screw			board ass'y <G>
A7	27141029	Bracket, pc board	A354	28185250	Side panel L <DN>		18560516-1B	NARF-2416-1B, Main circuit pc board ass'y <W>
A9	27190351A	Holder, power	A355	28185251	Side panel R <DN>	U2	18568517	NASW-2417-1, Power switch pc board ass'y <D>
A10	27190356	Holder, lid	A356	836440303	4STV+30CQ (BC), Special screw <DN>			board ass'y <D>
A11	27190405A	Holder ass'y	A357	870086	4x12BS (BC), Special washer <DN>		18564517A	NASW-2417-1A, Power switch pc board ass'y <G/W>
A12	28133145	Back plate				U3	18568518	NASW-2418-1, APR/Att. switch pc board ass'y
A13	28130231	Dial plate	A501	18568121	Front panel ass'y <S>	U4	18560519-1	NASW-2419-1, Band/Emphasis switch pc ass'y <W>
A14	27190353	Holder, dial plate		18578121	Front panel ass'y 	U6	18568520	NADG-2420-1, Digital circuit pc board ass'y <D>
A15	27190198B	Holder, lamp	A601	18579121	Front panel ass'y <DN> 			board ass'y <D>
A16	27273030C	Joint L	A602	27170156-1A	Bottom board		18564520A	NADG-2420-1A, Digital circuit pc board ass'y <G>
A18	27120761	Back panel <D>	A603	27175009A	Leg	U7	18568521	NADG-2421-1, Display circuit pc board ass'y
	27120762	Back panel <G>	A604	834430068	3TTS+6B (BC), Tapping screw	U8	18568522	NASW-2422-1, Memory switch pc board ass'y
	27120764	Back panel <W>	A605	834430108	3TTS+10B (BC), Tapping screw	U9	18564523	NAPL-2423-1, Lamp pc board ass'y
A19	27300750	Strainrelief	A801	28321904	Knob, power <S>	W901	253112	AS-UC-4 #18, Power supply cord <D>
A21	28140613	Cushion	A802	28321905	Knob, power 		253130 or 253128	AS-CEE, Power supply cord <G/W>
A24	838440089	4TTB+8C (BC), Tapping screw	A803	28322259	Knob A <S>			
A25	8344430068	3TTS+6B (BC), Tapping screw	PL001	28322260	Knob A 			
A26	831430088	3TTW+8B (BC), Tapping screw	S002	28320540	Knob L			
A27	833430080	3TTP+8P (BC), Tapping screw		210149	PL14V0.06AW-3.0, Lamp			
A28	8344430108	3TTS+10B (BC), Tapping screw		25065123	NSS-1258P, Voltage selector switch <W>			
A29	86414010	FWN4x10FN, Flange nut	T001	232098	NMA-3040, AM loop antenna			
A30	834230108	3TTS+10B (Ni), Nickel screw	T001a	27190129	Holder, antenna			
A31	82143006	3P+6FN (BC), Pan head screw	T901	2300026	NPT-893D, Power transformer <D>			
A32	831430100	3TTW+10P (BC), Tapping screw			NPT-893G, Power transformer <G>			
A33	8384430068	3TTB+6B (BC), Tapping screw			NPT-893DG, Power transformer <W>			
A51	82143006	3P+6FN (BC), Pan head screw <W>						
A52	82142604	2-6P+4F (BC), Pan head screw <W>						

NOTE: <D>: Only 120V model
 <DN>: Only U. S. A. model
 <G>: Only 220V model
 <W>: Only Universal model
 <S>: Only silver model
 : Only black model

NOTE: THE COMPONENTS IDENTIFIED BY MARK  ARE CRITICAL FOR RISK OF FIRE AND ELECTRIC SHOCK. REPLACE ONLY WITH PARTS NUMBER SPECIFIED.

MICROCOMPUTER OPERATION

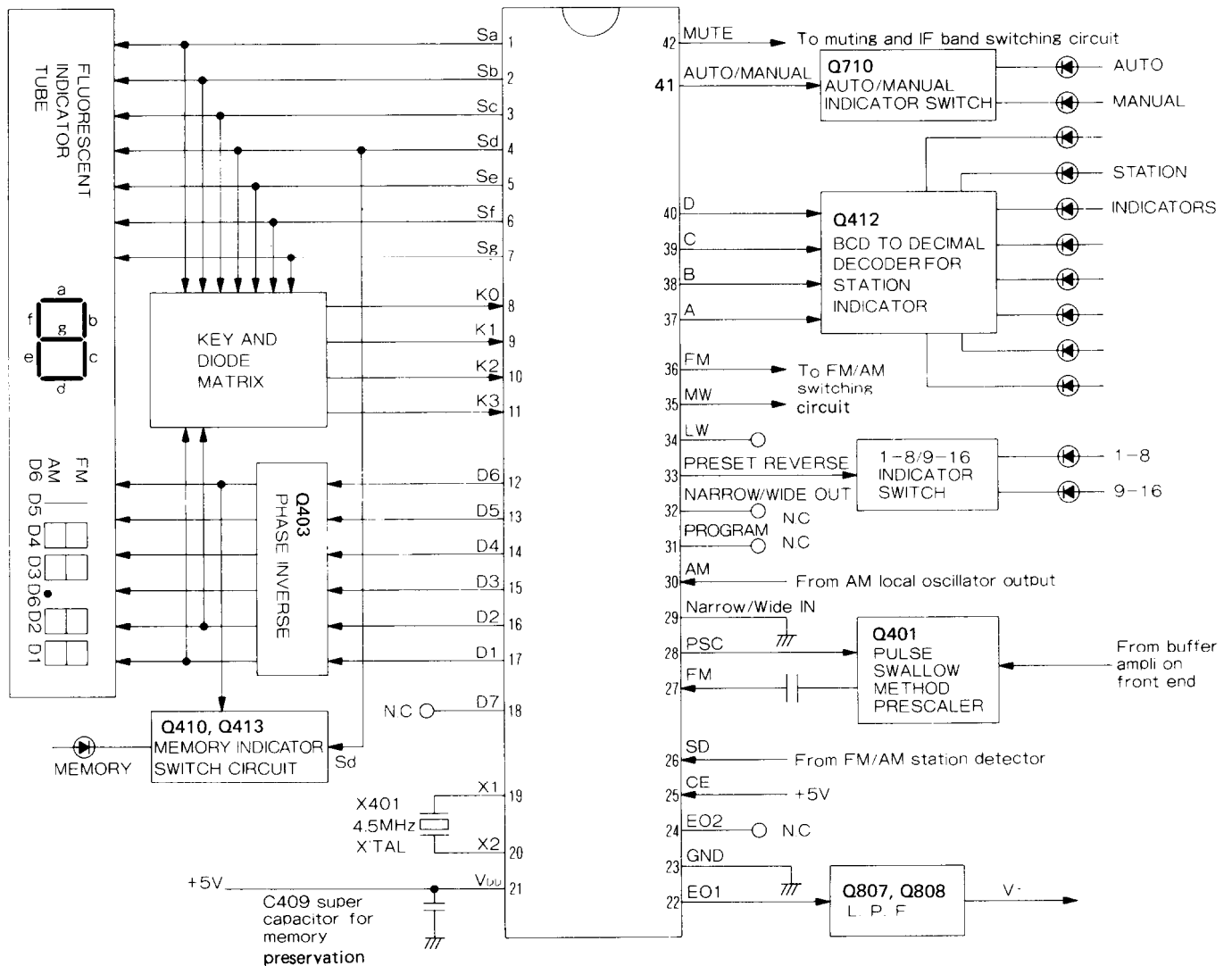

Pin No.	Symbol	Terminal	Description
1 - 7	Sa - Sg	Segment outputs	Display tube signal terminal output and key return signal source terminals; active high. Since these terminals can handle 30V, they are connected directly to the segment terminals of the fluorescent display tube.
8 - 11	K0 - K3	Key return signal inputs	Terminals for input of the key return signals from external matrix circuit.
12 - 18	D1 - D7	Digit outputs	Display tube digit output signal terminals; active low. D1 and D2 are used the key return signal source.
19, 20	X1, X2	X'tal	Connect to the 4.5MHz crystal oscillator.
21	V _{DD}	Power source input	Device power source terminal; supplies 5V during normal operation and 2.5V from the super capacitor C409 for memory preservation.

Pin No.	Symbol	Terminal	Description
22, 24	E01, E02	Error outputs	Charge pump output of the phase detector with constitutes the PLL. High level is output when the divided oscillation frequency is higher than the reference frequency. In the opposite case, low level is output. Floating occurs when the frequencies match. The output is applied to the variable capacitor diode in the front end through the low pass filter Q807 and Q808. The output from both terminals is same, but only E01 is used.
23	GND	Ground	
25	CE	Chip enable	Device selection signal input terminal. High level ... Normal operation Low level ... Memory preservation
26	SD	Station detector signal input	Input terminal for detecting whether or not a broadcast signal is being received during auto-tuning. Stopped by the high level.
27	FM	FM local oscillator signal input	Input terminal for FM local oscillator is divided by 1/16 or 1/17 by prescaler Q401.
28	PSC	Pulse swallow control output	This terminal outputs a signal that switches the prescaler division ratio of Q401 to 1/16 or 1/17 when the pulse swallow method is used for division. (FM only)
29	NARROW/ Wide out	IF band width output	Terminal for switching narrow and wide of IF band width. Not used.
30	AM	AM local oscillator signal input	Terminal for input of the AM local oscillator signal.
31	PROGRAM	Program selection signal output	Terminal for indicator output whether or not the program mode. Not used.
32	NARROW/ Wide out	IF band width switching output	Terminal for specifications output of IF band width. Not used.
33	Preset Reverse	Preset reverse indication output	Terminal for indication output whether M1 – M8 or M9 – M16 the preset key.
34	LW	Band switching signal outputs	Terminals for signal output switching of each band. High level is output from terminal of FM (pin no. 36) and low level is output from other terminals (pin no. 34 & 35) during FM reception. LW is not used with T-4087.
35	MW		
36	FM		
37 38 39 40	A B C D	Preset station indication outputs	Terminals for BCD code output of preset station indicator.
41	AUTO/ MANUAL	Auto/Manual indication output	Terminal for indication output whether or auto the tuning mode. This terminal becomes high during auto mode and low during manual mode.
42	MUTE	Muting output	Output terminal which mutes the shock noise occurring when the PLL is released; active high. The muting signal is output as shown below. UP/DOWN of manual/auto mode, preset memory is recalled, band switching and preset scan.

ADJUSTMENT PROCEDURES

FM SECTION

Item	Step	Connection of instrument	FM SG output	Stereo modulator output	Tuned Frequency	Output indicator	Adjustment point	Adjust	Remarks
Front End	1	Fig. 1	87.9MHz, 1kHz 75kHz devi. (108.0MHz) (G)		87.9MHz (D) 87.50MHz (G)	Digital DC voltmeter	T2	2.8 ± 0.4V	Usually not necessary to adjust. Repeat the steps 1 & 2 until no further adjustment is necessary.
	2				107.9MHz (D) 108.00MHz (G)	AC voltmeter	TC5	22.1 ± 0.4V	
	3					DC voltmeter 1	TC1 to TC4	Maximum	
FM IF	1	Fig. 2	99.1MHz, 65dBf 1kHz, 75kHz devi.		99.1MHz	DC voltmeter 1	L104	0V	Set the output volume on back panel to maximum position. IF Band Wide
	2					AC voltmeter DC voltmeter 2	L106	Maximum & 0V	
Signal indicator		Fig. 2	99.1MHz, 25dBf 1kHz, 75kHz devi.		99.1MHz	First L.E.D. of signal indicator	L102	Light on	
V.C.O		Fig. 3	99.1MHz, 65dBf No modulation		99.1MHz	Frequency counter	R205	76kHz ± 50Hz	
Stereo Distortion		Fig. 4	99.1MHz, 65dBf Ext. modulation	1kHz Lch Pilot signal 7.5kHz devi.	99.1MHz	Distortion analyzer	T1 on front end	Minimum	
				Lch.				Minimum	
Stereo Separation		Fig. 4	99.1MHz, 65dBf Ext. modulation	Lch.	99.1MHz	Rch. output Lch. output	R214	Minimum	IF band: Wide Same and maximum separation
				Rch.				Minimum	
Pilot Cancellor		Fig. 4	99.1MHz, 65dBf Ext. modulation	Lch.	99.1MHz	Rch. output Lch. output	R215	Minimum	IF band: Narrow Same and maximum separation
				Rch.				Minimum	
Muting level		Fig. 2	99.1MHz, 65dBf Ext. modulation	Only pilot Signal 7.5kHz devi.	99.1MHz	AC voltmeter	R212	Minimum	
				99.1MHz, 17.2dBf 99.1MHz, 16.2dBf				Oscilloscope	

AM Section

10kHz step model

Step	AM SG output	Tuned frequency	Output indicator	Adjust. point	Adjust for	Remarks
1		530 kHz	Digital DC voltmeter	L302	$2.0 \pm 0.1V$	Repeat the steps 1 and 2 until no further adjustment is necessary.
2		1620 kHz		TC302	$20 \pm 0.1V$	
3	600 kHz, 400 Hz 30% mod. 60 dB/m	600 kHz	AC voltmeter	L301	Maximum	Repeat the steps 3 and 4 until no further adjustment is necessary.
4	1400 kHz, 400 Hz 30% mod. 60 dB/m	1400 kHz		TC301	Maximum	
5	1000 kHz, 400 Hz 30% mod. 60 dB/m	1000 kHz	AC voltmeter	X301	Maximum	

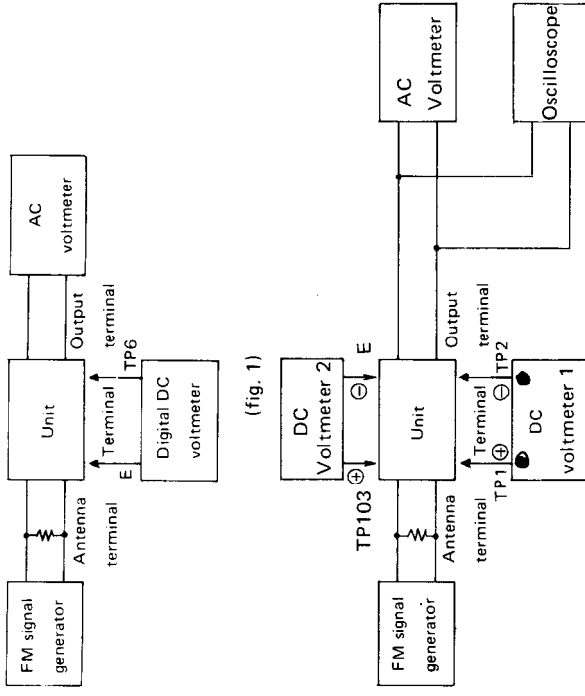

9kHz step models

Step	AM SG output	Tuned frequency	Output indicator	Adjust. point	Adjust for	Remarks
1		522 kHz	Digital DC voltmeter	L302	$1.8 \pm 0.1V$	Repeat the steps 1 and 2 until no further adjustment is necessary.
2		1611 kHz		TC302	$20 \pm 0.1V$	
3	603 kHz, 400 Hz 30% mod. 60 dB/m	603 kHz	AC voltmeter	L301	Maximum	Repeat the steps 3 and 4 until no further adjustment is necessary.
4	1404 kHz, 400 Hz 30% mod. 60 dB/m	1404 kHz		TC301	Maximum	
5	999 kHz, 400 Hz 30% mod. 60 dB/m	999 kHz	AC voltmeter	X301	Maximum	

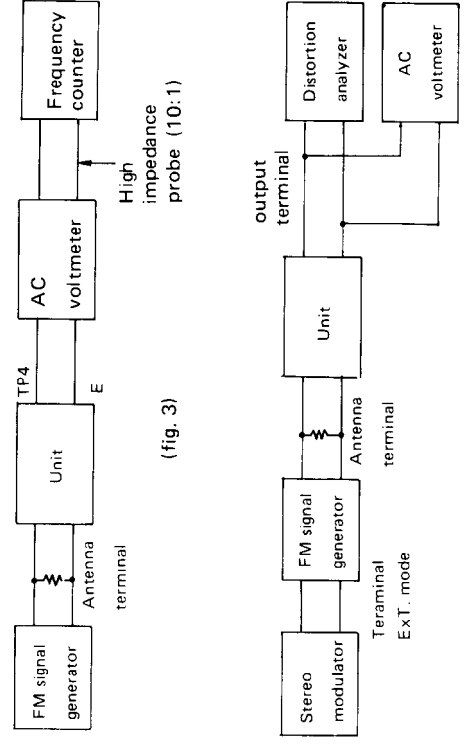

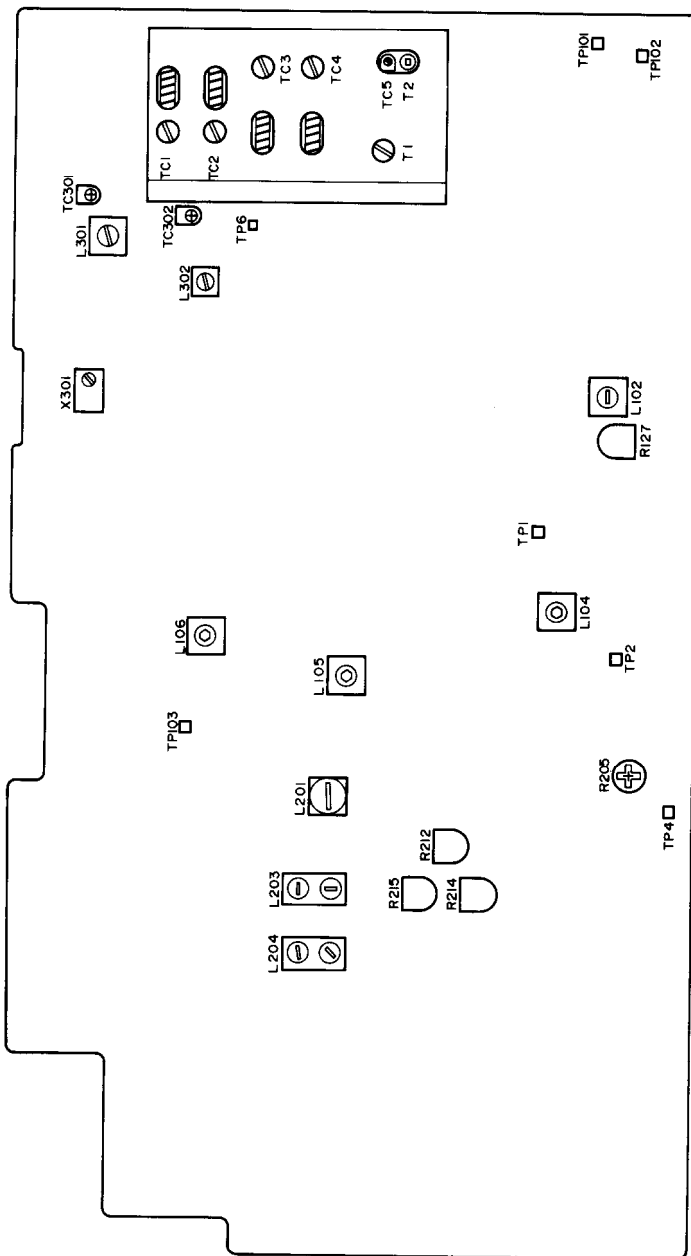
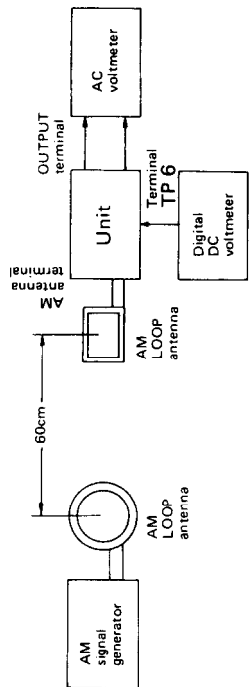

IC BLOCK DIAGRAM

μ PC1163H (FM IF amp.)

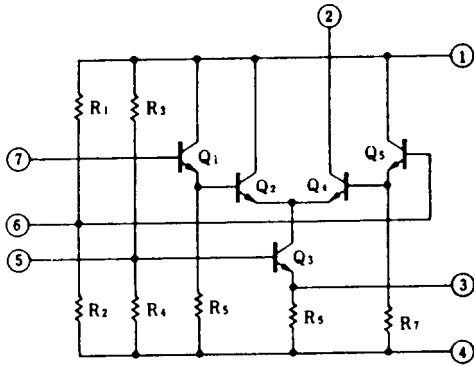

Terminal No.	Operation
1	Vcc
2	OUTPUT
3	BYPASS
4	GND
5	BYPASS
6	INPUT BIAS
7	INPUT

HA-11225(FM IF system)

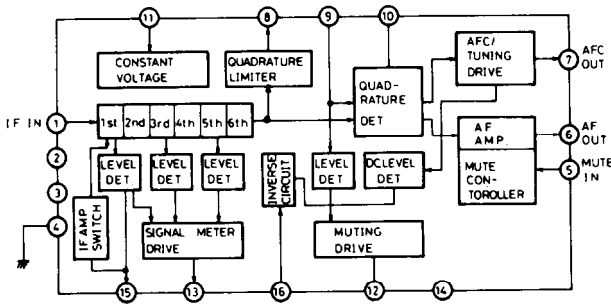

1. IF signal input
2. IF amplifier switch input
H level: Off
5. Muting switch input
6. Composite signal output
7. AFC output
8. IF amplifier output
9. 10.7MHz input
10. Reference voltage
11. Power supply
12. Muting output
Tuned: L level
13. Signal strength output
15. AGC out put
16. Muting level

4011B (Nand gate)

LOGIC DIAGRAM

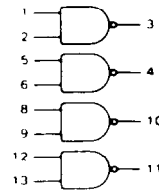

CIRCUIT SCHEMATICS
(1/4 of Device Shown)

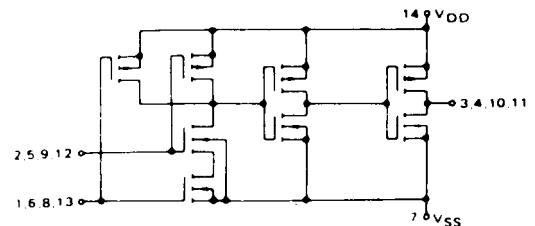

NJM-4558DX/NJM4560D
(Operation amplifier)

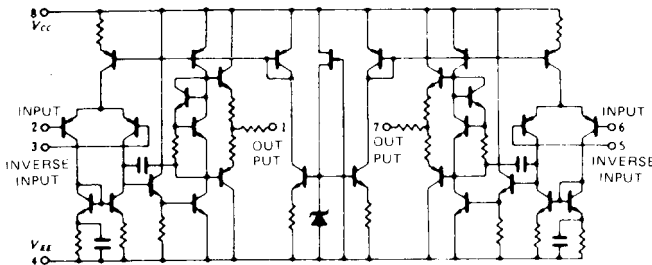

μ PC1223C (Stereo decoder)

Block diagram

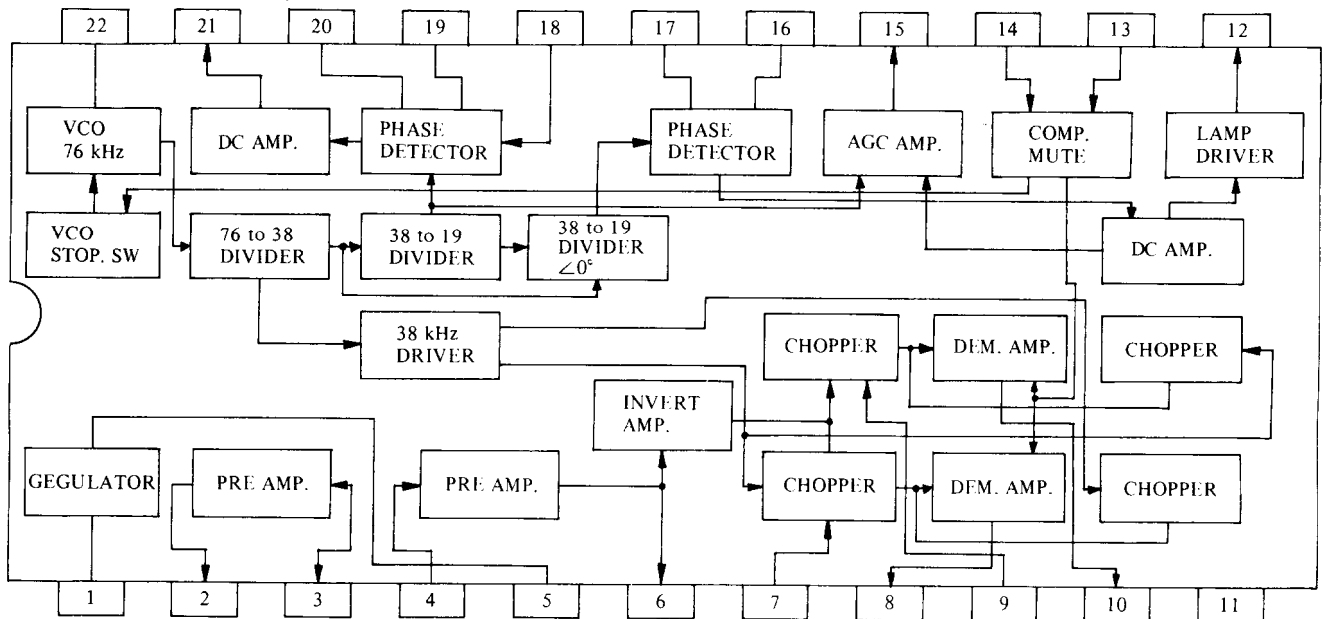

Terminal No.	Connection	Terminal No.	Connection
1	V _{cc}	12	ST. LAMP INDICATOR
2	PRE AMP. OUTPUT 1	13	ST-MONO SW & VCO STOP
3	PRE AMP. INPUT 1	14	MUTING SWS
4	PRE AMP. INPUT 2	15	19kHz CANCEL
5	BYPASS	16	LPF
6	PRE AMP. OUTPUT 2	17	LPF
7	POST AMP. INPUT	18	FILTER INPUT
8	L-ch OUTPUT	19	LPF
9	POST AMP. INPUT	20	LPF
10	R-ch OUTPUT	21	LPF
11	GND	22	OSC RC NETWORK

LB1403 (Signal strength indicator driver)

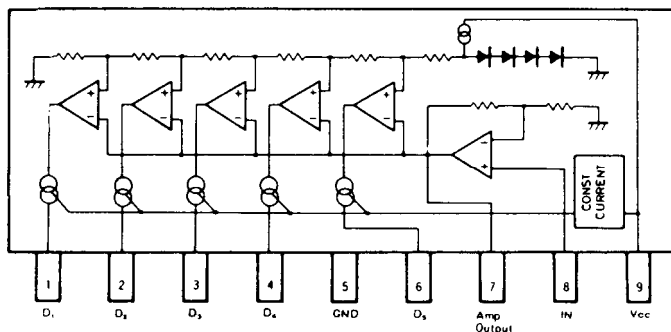

μPB553AC (Prescaler)

Pin Connection

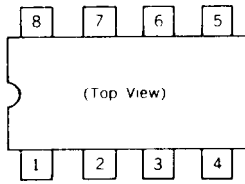

1. Pin 1 (Vcc)..... + 5 volts Supply
2. Pin 2 (IN).....FM local oscillator signal input
3. Pin 3 (CHK).....Check terminal
4. Pin 4 (GND).....Ground terminal
5. Pin 5 (OUT).....Prescaler terminal
6. Pin 6 (PSC).....Prescaler control terminal
7. Pin 7,8.....Not connected

Block Diagram

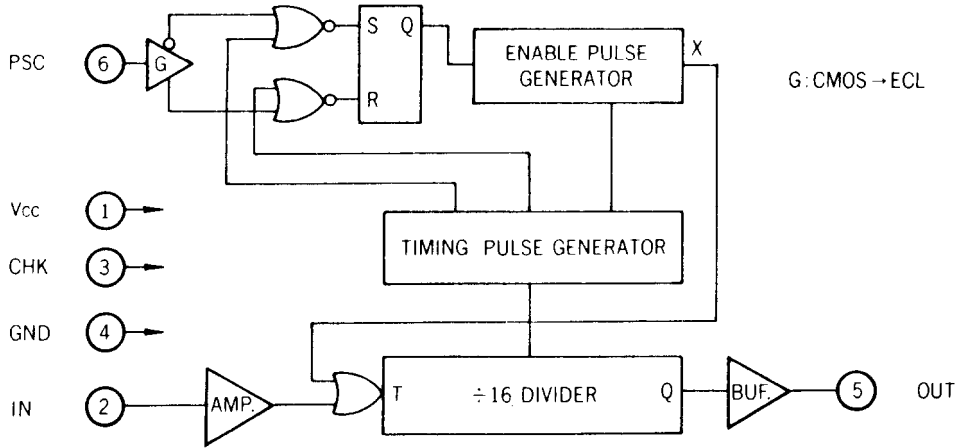

Timing Chart

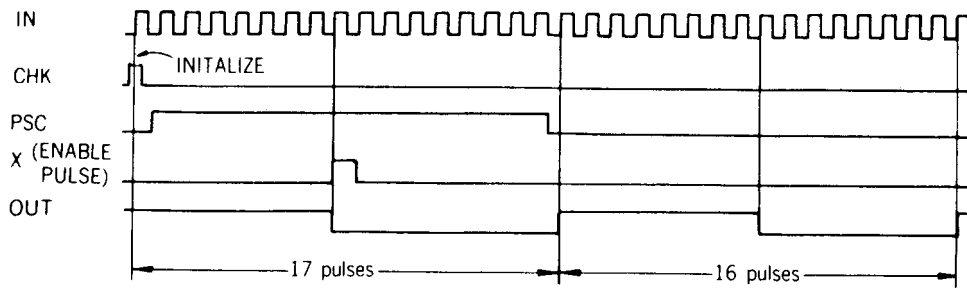

μPA81C (Indicator drive)

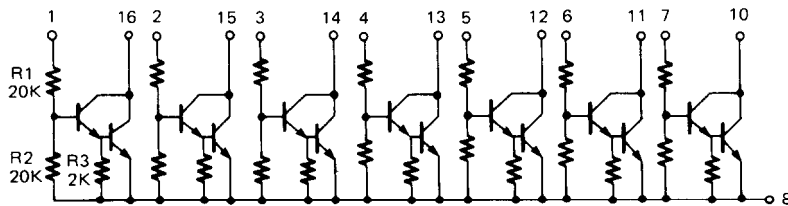

LA-1245 (AM radio system)

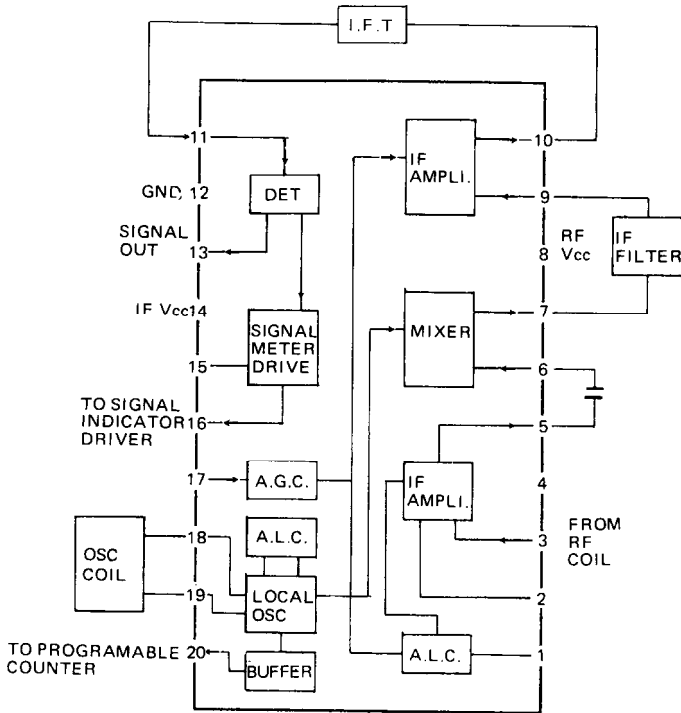

4538B (Dual precision retriggerable/resettable monostable multivibrator)

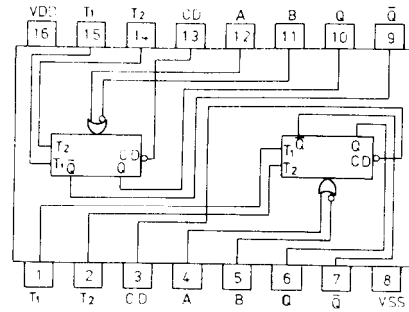

Truth Table

Input			Output	
A	B	CD	Q	\bar{Q}
H	H	H		
H	L	H	Q	\bar{Q}
L	H	H	Q	\bar{Q}
L	L	H		
X	X	L	L	H

X : Hor L

74LS42 (BCD to decimal decoder)

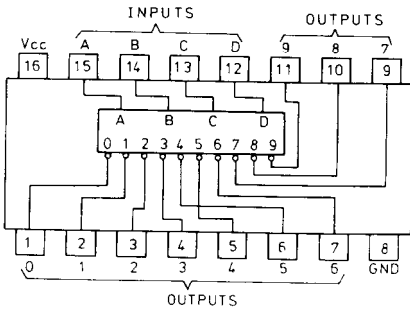

4013 (Dual D Flip-Flop with set/Reset capability)

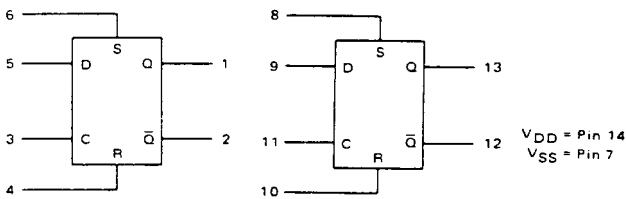

V_{DD} = Pin 14
V_{SS} = Pin 7

INPUTS				OUTPUTS	
CLOCK [†]	DATA	RESET	SET	Q	\bar{Q}
	0	0	0	0	1
	1	0	0	1	0
	X	0	0	Q	\bar{Q}
X	X	1	0	0	1
X	X	0	1	1	0
X	X	1	1	1	1

SCHEMATIC DIAGRAM

A B C D E F G H

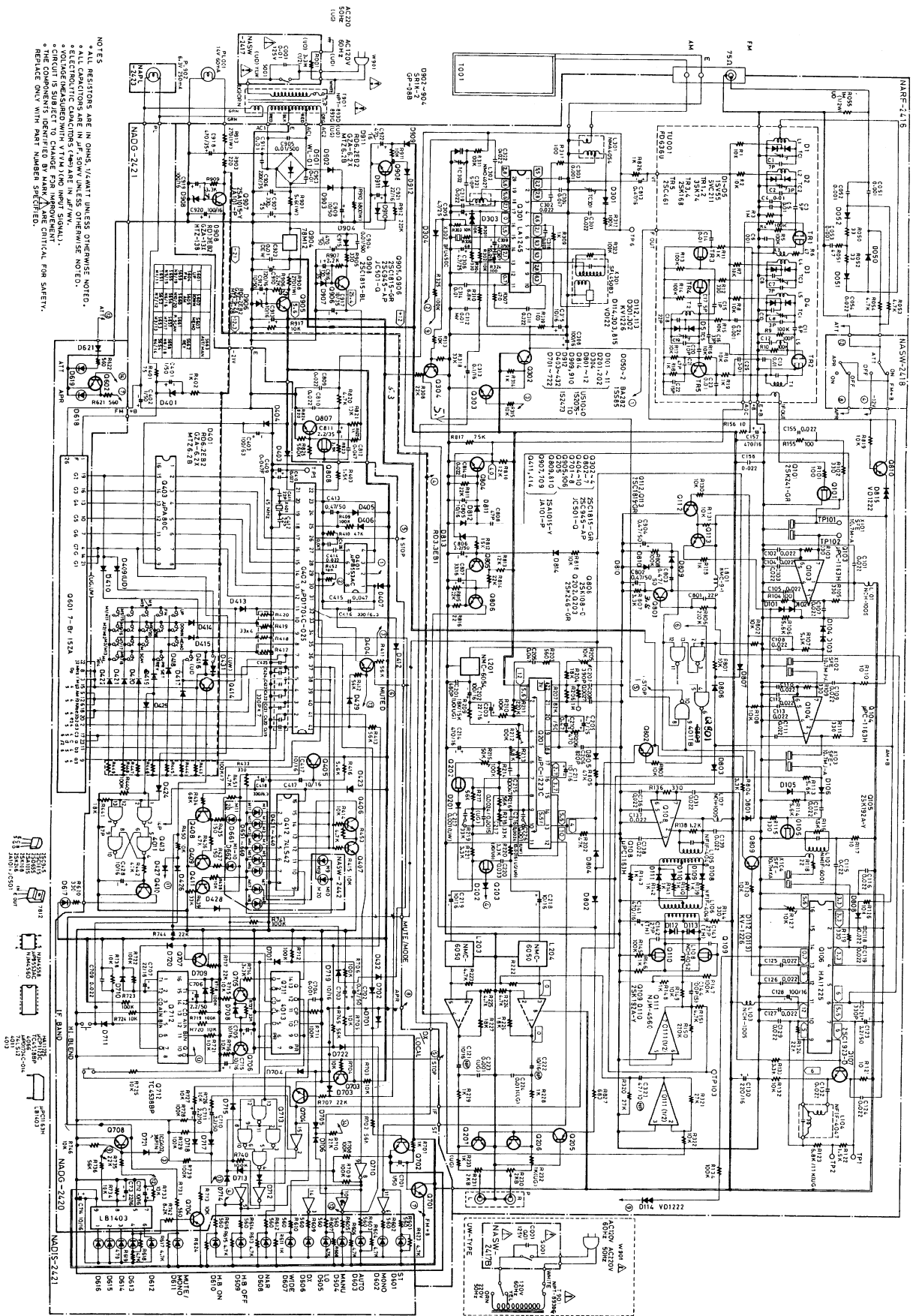

NOTES
* ALL RESISTORS ARE IN OHMS, 1/4WATT UNLESS OTHERWISE NOTED.
* ALL CAPACITORS ARE IN MICROFARADS UNLESS OTHERWISE NOTED.
* VOLTAGE MEASURED WITH VTK AND UNIT SIGNAL.
* CIRCUIT IS SUBJECT TO CHANGE FOR IMPROVEMENT.
* PARTS LISTED IN PART NUMBER ARE CRITICAL FOR SAFETY.
* REFERENCE ONLY WITH PART NUMBER SPECIFIED.

ONKYO CORPORATION

CHANGE OF PARTS

12. Nov., 8

MODEL T-4087

ONKYO CORP.
SERVICE DIVISION

TYPE	CIRCUIT NO.	DESCRIPTION	AFTER CHANGE SPECIFICATIONS		BEFORE CHANGE SPECIFICATIONS		CHANGE DESCRIPTION	APPLICATION
			DESCRIPTION	PART NO.	DESCRIPTION	PART NO.		
NARF-2416	R055	Solid resistor	1M Ω , 1/2W	431521055	Add between Ant. terminal & ground.		CSA	
		Label LA		29360168	Add			
NADG-2420	D413 JC701	Elect. capacitor Socket Socket	4.7 μ F, 25V NSCT-3P-395 NSCT-8P-100	352750479 25050267 25050272	0.47 μ F, 50V NJPS-3P-72 NJPS-8P-77	352784799 25050244 25050249	To stability initialize. Improvement of reliance.	2271-
NADG-2420B		Socket	NSCT-4P-96	25050268		25050245		
		Label CSA		29360117	Add			1601-

PRINTED CIRCUIT BOARD-PARTS LIST

MAIN CIRCUIT PC BOARD (NARF-2416-1/1A/1B)

CIRCUIT NO.	PART NO.	DESCRIPTION			
			L101, L103		Coils
			L107	233105	NCH-1005
			L108	233105	NCH-1005
			L201	233241	NCH-1052
			L203, L204	233350	NMC-6054
			L301	233320	NMC-6050
			L302	232120	NMA-4054
			L801	232110	NMO-4027
				233031	NMC-9-1
					Transformers
			L102	233096	NFIF-6001
			L104	233295	NFIF-4047
			L105	233296	NFIF-4048
			L106	233297	NFIF-4049
					Ceramic filters
			X101	3010043	SFE-10.7MM-A
			X102, X103	3010087	SFE-10.7MJ-A
			X104	3010041	SFE-10.7MX-A
			X301	3010075	SFL450B3
			X302	3010076	BFU450C
					Capacitors
			C123	352780229	2.2 μ F, 50V, Elect.
			C128	352741019	100 μ F, 16V, Elect.
			C130	352742219	220 μ F, 16V, Elect.
			C141	352744719	470 μ F, 16V, Elect.
			C144	372521014	100pF \pm 5%, 50V, Styrole
			C202	352741019	100 μ F, 16V, Elect.
			C203	352742209	22 μ F, 16V, Elect.
			C206	370138214	820pF \pm 5%, 100V, APS
			C207	370133914	390pF \pm 5%, 100V, APS
			C209	352750479	4.7 μ F, 25V, Elect.
			C210	352784799	0.47 μ F, 50V, Elect.
			C211	352741009	10 μ F, 16V, Elect.
			C214	352744719	470 μ F, 16V, Elect.
			C216, C217	379122424	2,400pF \pm 5%, 50V, DEW
				379121524	<D> 1,500pF \pm 5%, 50V, DEW
					<G/W>
			C218, C219	352741009	10 μ F, 16V, Elect.
			C221, C222	352941006	10 μ F, 16V, Non-polar elect.
			C223, C224	379121025	1,000pF \pm 20%, 50V, DEW
			C226, C227	379121024	1,000pF \pm 5%, 50V, DEW
					<W>
			TC301, TC302	3060010	NTC-20P09, Trimmer
			C305, C306	352750479	4.7 μ F, 25V, Elect.
			C308	352741019	100 μ F, 16V, Elect.
			C309	352780229	2.2 μ F, 50V, Elect.
			C313	352781099	0.1 μ F, 50V, Elect.
			C315	352741009	10 μ F, 16V, Elect.
			C321	370135114	510pF \pm 5%, 100V, APS
			C323	352944706	47 μ F, 16V, Non-polar elect.
			C802-C804	352784799	0.47 μ F, 50V, Elect.
			C805	352741009	10 μ F, 16V, Elect.
			C806	352780229	2.2 μ F, 50V, Elect.
			C807	352743309	33 μ F, 16V, Elect.
			C811	395160227	2.2 μ F, 35V, Tantalum
			C813	352784799	0.47 μ F, 50V, Elect.
			C905	384171037	0.01 μ F, 630V, DT
			C906	352762229	2,200 μ F, 35V, Elect.
			C907	352753319	330 μ F, 25V, Elect.
			C909	352781009	10 μ F, 50V, Elect.
			C910	352742219	220 μ F, 16V, Elect.
			C912, C913	352741009	10 μ F, 16V, Elect.
			C915	352784719	470 μ F, 50V, Elect.
			C916	352761019	100 μ F, 35V, Elect.
			C917	352761009	10 μ F, 35V, Elect.
			C918	352764719	470 μ F, 35V, Elect.
TU001	240062	BFD636U12			
					Front end
					ICs
Q103, Q104	222474	μ PC1163H			
Q106	222540	HA-11225			
Q108	222474	μ PC1163H			
Q111	222579	NJM4560D			
Q201	222732	μ PC1223C			
Q204	222502	NJM4558DX			
Q301	222701	LA1245			
Q801	222513 or 222840111	TC4011BP or 4011BP			
Q904	222780122	78M12			
					Transistors
Q101	2212194 or 2212195	2SK241 (Y) or 2SK241 (GR)			
Q105	2212274	2SK192A (Y)			
Q107	2211722 or 2211723	2SC1923 (R) or 2SC1923 (O)			
Q109, Q110	2212274	2SK192A (Y)			
Q112, Q113	2211255,	2SC1815 (GR),			
Q302-Q304	2210746 or	2SC945A (P) or			
Q802-Q807	2212485	JC501 (Q)			
Q202, Q203	2211944 or 2211945	2SK246 (Y) or 2SK246 (GR)			
Q205, Q809	2211454 or	2SA1015 (Y) or			
Q810, Q907	2212494	JA101 (P)			
Q206, Q207	2211704, 2211705 or 2211706	2SD655 (D), 2SD655 (E) or 2SD655 (F)			
Q808	2212294	2SK108 (D)			
Q905, Q906	2211255, 2210746 or 2212485	2SC1815 (GR), 2SC945A (P) or JC501 (Q)			
Q908	2211256	2SC1815 (BL)			
					Diodes
D050-D052	223165 or 223149	BA282 or 1S585			
D101-D106	223150,	US1040,			
D108-D111	223145 or	1S2076TD or			
D201, D202	223124	1S2473			
D112, D113	223136	KV1226			
D114, D815	4000068	VD1222			
D301, D302	223136	KV1226			
D303	4000068	VD1222			
D304, D814	223150,	US1040,			
D801-D812	223145 or 223124	1S2076TD or 1S2473			
D813	2241291	RD3.3EB1			
D901	223862	WL-01			
D902-D904	223804 or 223848	SR1K-2 or GP08B			
D906, D911	2239492, 2240971 or 2243162	RD6.2EB2, GZA-6.2X or MTZ6.2B			
D907	2239792	RD27EB2			
D908	2239652, 2241131 or 2243242	RD13EB2, GZA-13X or MTZ-13B			
D909, D910	223150,	US1040,			
D912	223145 or 223124	1S2076TD or 1S2473			

C919	352751019	100 μ F, 25V, Elect.
C920	352741019	100 μ F, 16V, Elect.
C921	352742209	22 μ F, 16V, Elect.
C922	352744719	470 μ F, 16V, Elect.
C923	379121045	0.1 μ F \pm 10%, 50V, DEW
Resistors		
R127	5215045	N08HR10KBC, Semi-fixed
R205	5225015	N10HR10KBD, Semi-fixed
R212	5215047	N08HR100KBC, Semi-fixed
R214	5215047	N08HR100KBC, Semi-fixed
R215	5215046	N08HR50KBC, Semi-fixed
R230	5146046	N16RGL2KB15, Output level variable
R901	441620564	5.6 Ω , 1W, Metal oxide film
R908	441622714	270 Ω , 1W, Metal oxide film
R910	441626814	680 Ω , 1W, Metal oxide film
R913	441622714	270 Ω , 1W, Metal oxide film
Terminals		
	25060087	NT-2PDMN31, Antenna
	25045141	NPJ-2PDBL54, Output
Radiator		
	27160179	RAD-057
Screw		
	82143006	3P+6FN (BC), Pan head

POWER SWITCH PC BOARD (NASW-2417-1/1A)

CIRCUIT NO.	PART NO.	DESCRIPTION
C001	Δ 3500065A	DE7150FZ103PAC400V/125V, Capacitor 1S
R001	Δ 431523355	3.3M Ω , 1/2W, Resistor, solid <D>
S001	Δ 25035295	NPS-111-L261P, Power switch

APR/ATT. SWITCH PC BOARD (NASW-2418-1)

CIRCUIT NO.	PART NO.	DESCRIPTION
S004, S005	25035494	NPS-222-L456, Push switches

**BAND/EMPHASIS SWITCH PC BOARD (NASW-2419-1)
<Only Universal model>**

CIRCUIT NO.	PART NO.	DESCRIPTION
S003	25065240	NSS-42102, Slide switch

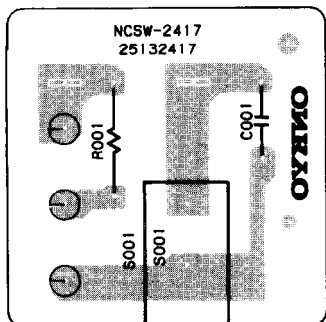

POWER SWITCH PC BOARD



APR/ATT. SWITCH PC BOARD

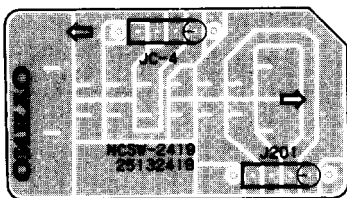

BAND/EMPHASIS SWITCH PC BOARD

NOTE: THE COMPONENTS IDENTIFIED BY MARK Δ ARE CRITICAL FOR RISK OF FIRE AND ELECTRIC SHOCK. REPLACE ONLY WITH PARTS NUMBER SPECIFIED.

PRINTED CIRCUIT BOARD VIEW FROM BOTTOM SIDE

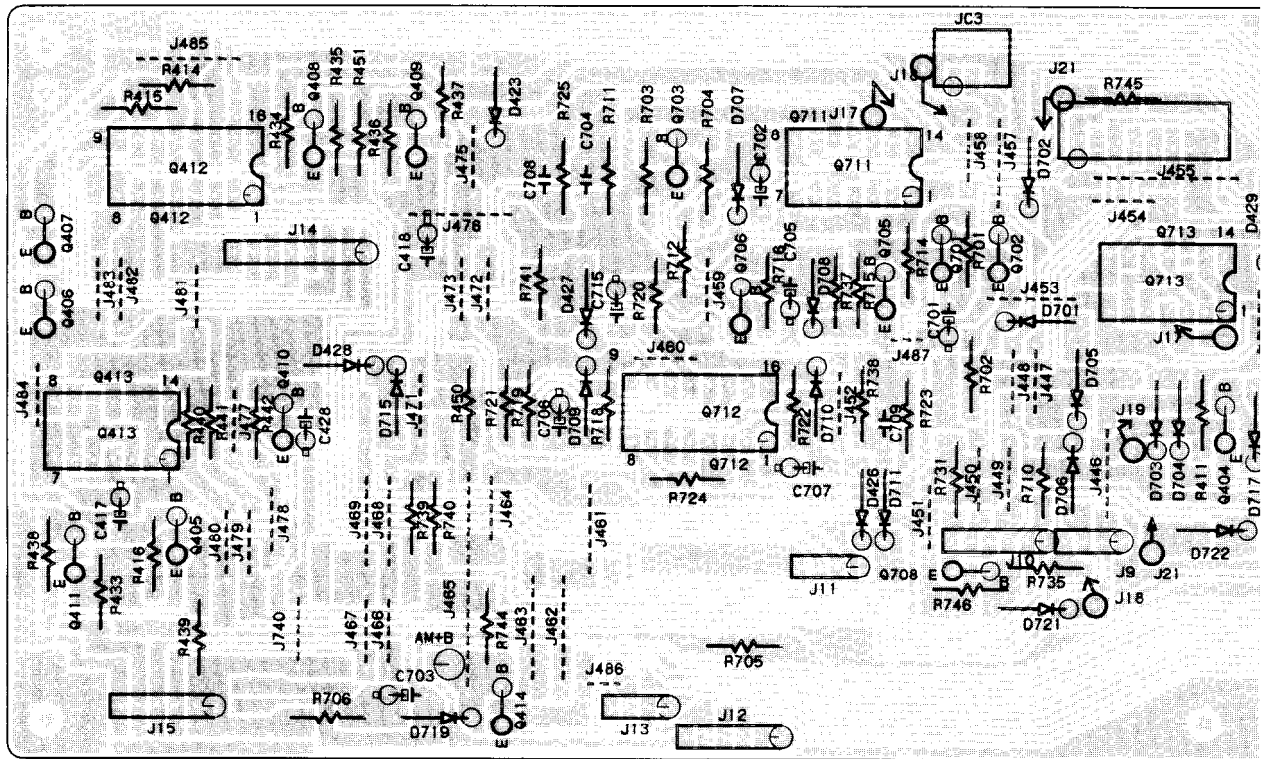

DIGITAL CIRCUIT PC BOARD (NADG-2420-1/1A/1B)

CIRCUIT NO.	PART NO.	DESCRIPTION
ICs		
Q401	222619	μ PB553AC
Q402	222763	μ PD1704C-025
Q403	222801	μ PA80C
Q412	222740421	74LS42
Q413, Q713	222513 or 222840111	μ PD4011BP or 4011BP
Q710	222807	μ PA81C
Q711	222840131	4013B
Q712	222850381	4538B
Q714	222670 or 222666	BA6124 or LB1403
Transistors		
Q404-Q410	2211255,	2SC1815 (GR),
Q701-Q708	2210746 or 2212485	2SC945A (P) or JC501 (Q)
Q414, Q710	2211454 or	2SA1015 (Y) or
Q411, Q709	2212494	JA101 (P)
Diodes		
D401	2240971 or 2239492	GZA-6.2X or RD6.2EB2
D403-D407	223150,	US1040,
D412-D415	223145 or	1S2076TD or
D417-D429	223124	1S2473
D409, D416	223150,	US1040,
	223145 or	1S2076TD or
	223124	1S2473 <D>
D410	223150,	US1040,
	223145 or	1S2076TD or
	223124	1S2473 <G>

D430, D431	223150, 223145 or 223124	US1040, 1S2076TD or 1S2473 <W>
D432, D722	223150,	US1040,
D701-D715	223145 or	1S2076TD or
D717-D720	223124	1S2473
D721	223132	1K60
X' tal		
X401	3010091	XTL-4.5M
Capacitors		
C401, C402	352780109	1 μ F, 50V, Elect.
C403	352721019	100 μ F, 6.3V, Elect.
C409	3020018	0.047F, 5V, Super
C416	352723319	330 μ F, 6.3V, Elect.
C417	352741009	10 μ F, 16V, Elect.
C418	352723319	330 μ F, 6.3V, Elect.
C419-C424	3020024	B8xC0116-32N, Block
C428	352741009	10 μ F, 16V, Elect.
C701	352780109	1 μ F, 50V, Elect.
C702	352784799	0.47 μ F, 50V, Elect.
C703, C705	352741009	10 μ F, 16V, Elect.
C706	352780229	2.2 μ F, 50V, Elect.
C707	352742209	22 μ F, 16V, Elect.
C710, C711	352780229	2.2 μ F, 50V, Elect.
C712	352741009	10 μ F, 16V, Elect.
C713	352742209	22 μ F, 16V, Elect.
C714, C715	352741009	10 μ F, 16V, Elect.
Resistors		
R417-R420	49121333504	33k Ω x4, 1/8W, Network
R443-R449	49121104507	100k Ω x7, 1/8W, Network
Sockets		
JC701	25050244	NJPS-3P-72
JC702	25050249	NJPS-8P-77
	25050245	NJPS-4P-73 (W)

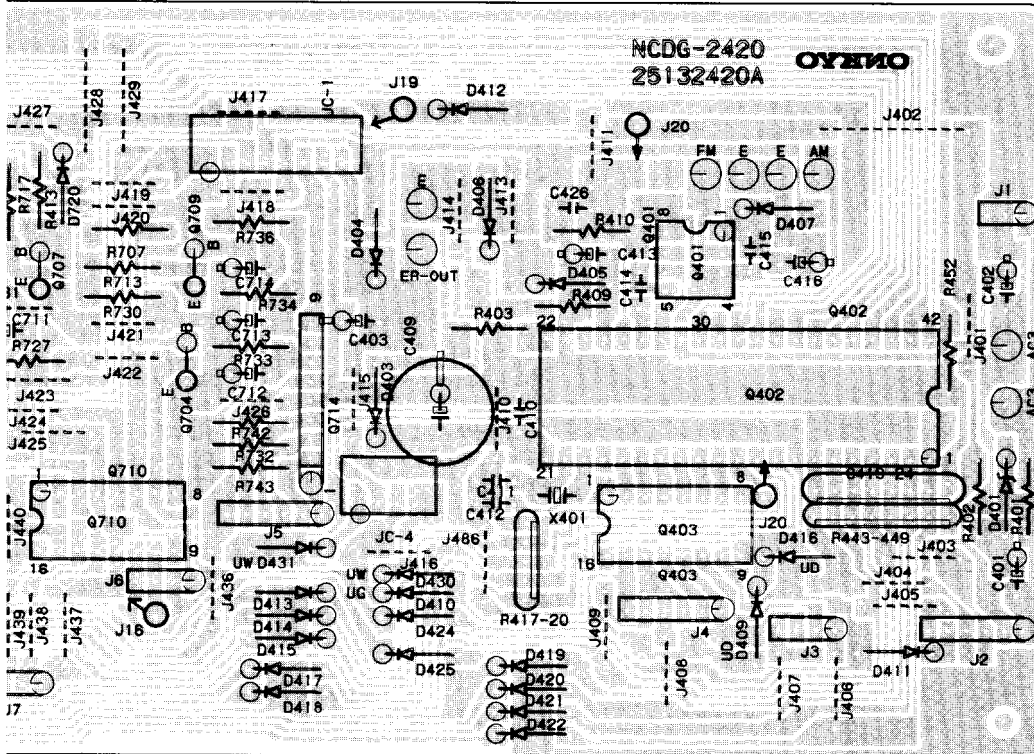

DIGITAL CIRCUIT PC BOARD

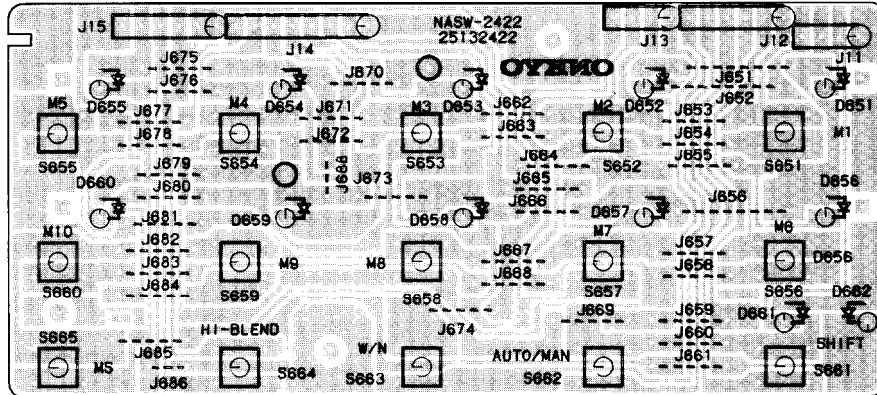

MEMORY SWITCH PC BOARD

MEMORY SWITCH PC BOARD (NASW-2422-1)

CIRCUIT NO.	PART NO.	DESCRIPTION
	L. E. Ds	
D651-D660	225141	SEL2213C
D661	225137CG,	SEL2413E-CG,
	225137DG or	SEL2413E-DG or
	225137DY	SEL2413E-DY
D662	225142	SEL2913K
	Switches	
S651-S665	20535389	NPS-111-S353
	Holders	
	27190355A	LED 5
	27190249	LED

LAMP PC BOARD (NAPL-2423-1)

CIRCUIT NO.	PART NO.	DESCRIPTION
PL902	210064A	PL6.3V, 250mA

PRINTED CIRCUIT BOARD VIEW FROM BOTTOM SIDE

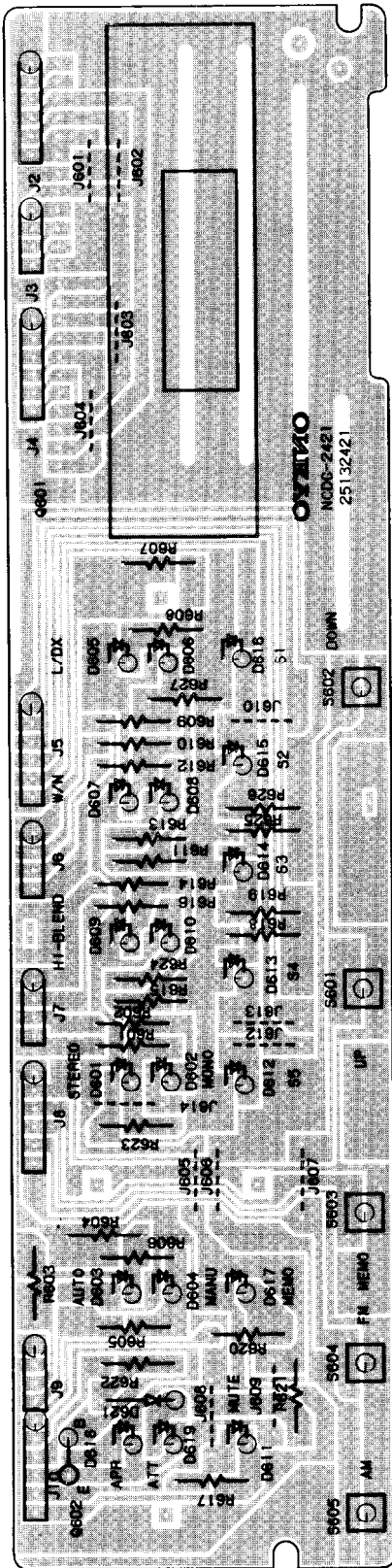

DISPLAY CIRCUIT
PC BOARD

DISPLAY CIRCUIT PC BOARD (NADG-2421-1)

CIRCUIT NO.	PART NO.	DESCRIPTION
Fluorescent indicator tube		
Q601	212018	7-BT-15ZA
Transistor		
Q602	2211255, 2210746 or 2212485	2SC1815 (GR), 2SC945A (P) or JC501 (Q)
L. E. Ds		
D601, D617	225141	SEL2213C
D602, D606	225142	SEL2913K
D608, D610	225142	SLE2913K
D619, D604	225142	SEL2913K
D603, D605	225137CG,	SEL2413E-CG,
D607, D609	225137DG or	SEL2413E-DG or
D611-D616	225137DY	SEL2413E-DY
D618		
Diode		
D621	223150, 223145 or 223124	US1040, 1S2076TD or 1S2473
Switches		
S601-S605	25035389	NPS-111-S353
Holder		
	27190404	L. E. D
Cushion		
	28140597	1.5 x 10 x 40mm

PACKING VIEW

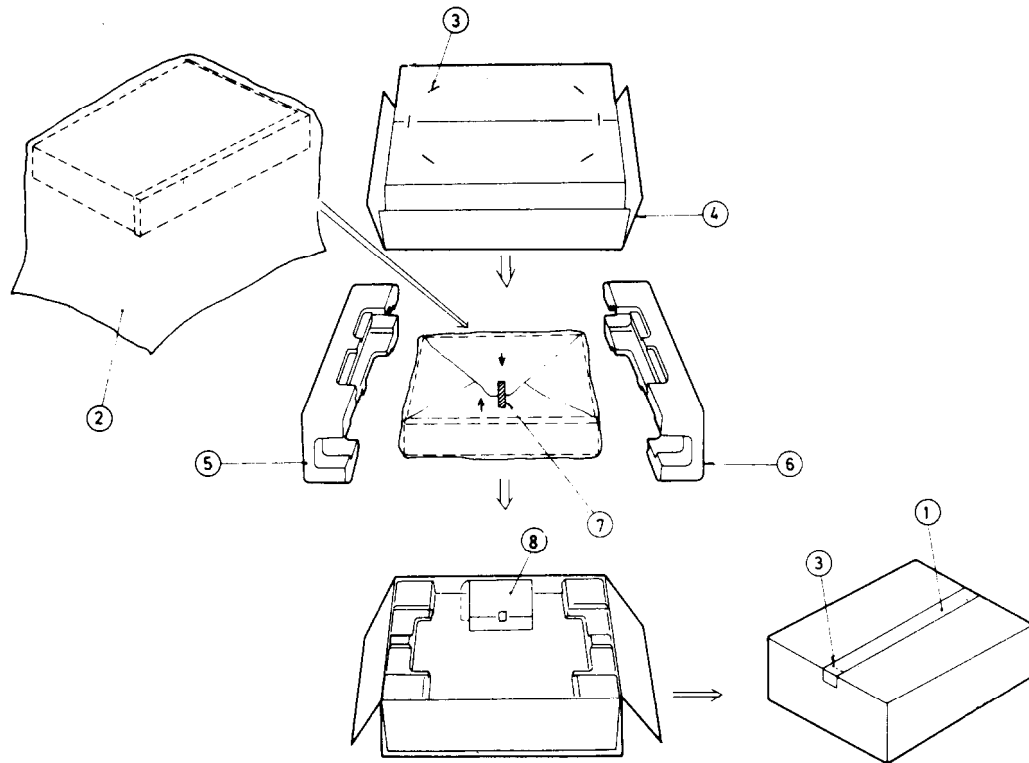

REF. NO.	PART NO.	DESCRIPTION	PART NO.	DESCRIPTION
1	29095012-1	500x800mm, Protection sheet	120V model	
	29095318	500x800mm, Protection sheet (U.S.A model)	292092	FM antenna
2	29100036A	550x850mm, Poly-vinyl bag	2010095	Connection cable
3	282301	Sealing hook	25060088	FM adaptor
4	29051200	Master carton box	29340932	Instruction manual
	29051201	Master carton box (black model)	220V model	
	29051243	Master carton box (U.S.A. model)	292092	FM antenna
5	29090772A	Pad R	2010095	Connection cable
6	29090771A	Pad L	25060088	FM adaptor
7	29110032	Adhesive tape	29340933	Instruction manual
8	260012	50x700mm, Damplon tape	120/220V model	
	Accessory bag complete		292092	FM antenna
	U. S. A. model		2010095	Connection cable
	292092	FM antenna	25060088	FM adaptor
	29340932	Instruction manual	29340933	Instruction manual
	2010095	Connection cable	25055040	CV-K-2, Conversion plug
	25060088	FM adaptor		
	29365006-7	Warranty card		
	29358002C	Service station list		

ONKYO CORPORATION

International Division: No.24 Mori Bldg., 23-4, 3-chome, Nishi-Shinbashi, Minato-ku, Tokyo, Japan.
Telex: 2423551 ONKYO J. Phone: 03-432-6981

ONKYO U.S.A. CORPORATION

200 Williams Drive, Ramsey, N.J. 07446 Tel. 201-825-7950